

Maverick Service Centers

USA

Maverick

Products Serviced:

All Maverick frames, forks,
and components

3085 Bluff St.

Boulder, CO 80301

tech@maverickbike.com

(P) 303-415-0370

(F) 303-415-0379

Suspension Experts, Inc.

Products Serviced:

All Maverick frames, forks,
and components

89 Thompson St., Unit K

Asheville, NC 28803

kevin@mtbsuspensionexperts.com

(P) 866-800-2453

The Fix

Products Serviced:

All Maverick frames, forks,
and components

3085 Bluff St.

Boulder, CO 80301

service@thefixbike.com

(P) 303-939-8349

Germany

Toxaholics

Products Serviced:

All Maverick frames, forks,
and components

Hauptstr. 200

D-66876 Rodalben

toxaholics@t-online.de

(P) 06331258160

Italy

Area B di Modolo Valter

Products Serviced:

All Maverick frames, forks,
and components

Via Galvaligi 6/D

31058 Susegana (TV)

info@areab.it

(P) 039 (0) 438 435 550

United Kingdom

Extra Ltd.

Products Serviced:

All Maverick frames, forks,
and components

Datamex House, Morris Close

Park Farm Ind. Estate, Wellingborough

Northants NN8 6XF

service@extrauk.co.uk

(P) 01933 672170

(F) 01933 672171

TF Tuned Shocks

Products Serviced:

DUC32 and SC32 forks;

SpeedBall seatposts

www.tftuned.com

(P) 01373 834455

South Africa

Pedal-on Marketing CC

Products Serviced:

All Maverick frames, forks,
and components

Shop 6A

8 Old Main Road

Hillcrest, KwaZulu Natal 3610

kzn@maverickworld.co.za

(P) +27 31 767 6222

(F) +27 31 767 5501

Maverick



Owner's Manual

Maverick

MAVERICKBIKE.COM

3085 Bluff Street Boulder, Colorado 80301 Tel : 303.415.0370 Fax : 303.415.0379

WARRANTY

Your new Maverick frame is warranted to the original consumer against defects of workmanship and materials from the original purchase date for a period of: three years for the shock and suspension moving parts; and five years for the frame tubes and structural components. Should there be a defect or malfunction of this product, Maverick will repair or replace it, at Maverick's option, free of charge. This warranty does not cover the labor cost of component removal or re-assembly, nor does it cover costs of shipping to Maverick. Maverick will cover return shipping and handling costs. All warranty coverage is based on the product being properly maintained and adjusted (as detailed in the owner's manual), and ridden in the manner described below. There are no expressed warranties other than those stated herein.

Maverick frames are designed and tested for riding in rough and demanding off-road terrain. While some jumping is expected to clear natural obstacles, Maverick frames are not built to withstand jumping from man-made ramps or other daredevil feats. This warranty is void if the product has been subject to damage, unreasonable use, improper service, or other causes not arising from defects in original material or workmanship.

This warranty does not include adjustments, parts or repairs required by circumstances beyond the control of Maverick, including but not limited to leakage damage. Normal wear and tear is not covered by this limited warranty.

It is our desire to make life with your Maverick product trouble free, so we want to eliminate any hassles you might have with a warranty issue. To achieve a fair and liberal warranty program, you, the customer, must be fair too. Even if you have a failure from crashing or lack of proper maintenance, we will work with you to minimize the cost of repairs if you are honest about what happened. In cases of crashes or accidents, you will be offered repairs or replacement under Maverick's Crash Replacement Program.

Any expressed or implied warranties, including but not limited to merchantability and fitness for a particular purpose are limited to the above one-year warranty period. Maverick shall not be liable for any incidental or consequential cost, expenses or damages resulting from the any failure defect or malfunction of this product. Some states do not allow the exclusion or limitations of implied warranties or consequential damages, therefore, the above limitations may not apply to you. This warranty grants you specific legal rights, and you may also have other rights that vary from state to state.

RETURN PROCEDURE

Return of a product, for any reason, must be associated with a Return Authorization Number (RA#). An RA# can be obtained by contacting Maverick directly at 303-415-0370 or warranty@maverickbike.com. Maverick will not accept responsibility for any frames returned to Maverick without an RA#. You should insure your shipment for its full value. If returning a frame, please follow these instructions:

1. Remove all products from the frame that are not part of the warranty work.
2. Take extra care to package the product in a sturdy cardboard box. Maverick will not be responsible for damage to products caused by improper packaging.
3. Mark the Return Authorization Number clearly on the outside of the box and address as follows:
 - RA# (Fill in Number)
 - Maverick
 - 3085 Bluff Street
 - Boulder, CO 80301
4. Include a copy of your original purchase receipt.
5. Be sure to include a copy of your contact information inside the box.

SUSPENSION PIVOTS



BB LINK BEARINGS:

After approximately 250 hours of riding (6 - 12 months), the bearings in the BB link should be re-greased. If you ride often in very muddy conditions, you may want to perform this task more frequently. It will require taking off the drive-side crank arm which may require a special removal tool. Otherwise this service is easy and a good set of tools is all that is needed.

- 1) Remove the right crank arm and take out the two link bolts. Hold the link nut with a 15mm wrench and turn the link bolt from the left side with a strong 6mm hex wrench.
- 2) Pull the BB Link out of the frame. You will need to disconnect the derailleur to completely remove the BB Link, but the re-greasing can be done with it still attached.
- 3) Gently pry out the rubber seals covering the bearings using a safety pin or dull knife. Note which side of the seal faces outward.
- 4) Add a small amount of heavy duty, non-lithium grease to the inside of the bearings and replace the seals with your fingers.
- 5) Re-install the BB Link



TOP SHOCK PIVOT:

After approximately 100 hours of riding (6 months), the Top Shock Pivot should be re-greased. This requires two 5mm hex wrenches and should only take 10 minutes.

- 1) Remove the Top Shock Mounting Bolts using a 5mm Hex wrench on either side, and pull the shock away from the frame.
- 2) Push the steel pivot sleeve out of the frame.
- 3) Clean the pivot Sleeve, bushings and O-rings and re-pack with a heavy duty, non-lithium grease.
- 4) Re-assemble, being careful not to lose or damage the thin O-ring that sits between the frame and shock mount clevis.

REAR SHOCK

After approximately 250 hours of riding (6 - 12 months), the rear shock damper should be removed to clean the wiper seal and replace the lubrication oil. This will greatly improve the performance and life of the suspension. The process is very easy, requires no special tools and should take less than an hour.

- 1) WASH THE BIKE! This will prevent dirt falling into the open shock.
- 2) Release the air pressure from the shock - VERY IMPORTANT!
- 3) Remove the top shock mounting bolt using two 5mm hex wrenches and pull the shock away from the frame. Remove the shock boot.
- 4) With a 4mm hex wrench, loosen the two set screws located on either side of the shock body.
- 5) Pull the damper out of the shock body. This may require loosening or removing the derailleur and brake cables to allow the rear triangle to swing back enough for the damper to clear the frame.
- 6) Clean the wiper seal, bushings and old oil from the shockbody using a clean, lint-free rag.

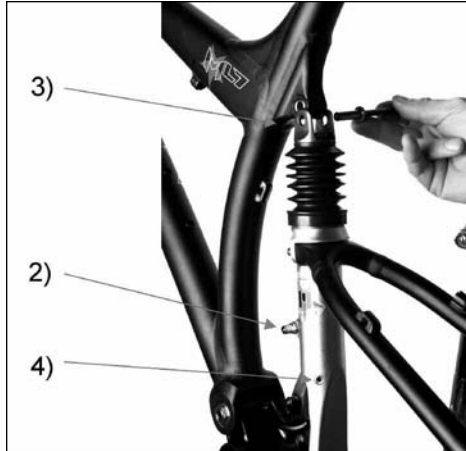

Damper installation:

- 1) ML7: Add 7 ml of Maverick "Gunna Flow" or 80w GL5 oil into the shock body.
ML7/5: 10 ml; ML8: 15 ml.
- Apply a small additional amount to the wiper lips and bushings.
- 2) Slide the damper back into the shock body, being careful not to invert the wiper lips as you do so. This may require cocking the damper slightly sideways to get one edge of the tube in first.
 - 3) After the tube is past the seals it should slide in smoothly. Push the damper all the way to the bottom while releasing the schrader valve to allow air to escape from the shock.
 - 4) With the damper held at the bottom, tighten the two set screws. If they thread in too far, or hardly at all, then the damper may not be fully in and seated.
 - 5) Replace the shock boot and re-install the top shock mount.

TABLE OF CONTENTS

Frame Specifications	Section-1
<ul style="list-style-type: none">• Features and Terms• Exploded Views	
Assembly Information	Section-2
<ul style="list-style-type: none">• Overview• Required Components• Cable Routing• Misc.	
Suspension Set-up	Section-3
<ul style="list-style-type: none">• Shock Pressure• Damper Adjustments• Advanced Tuning	
Maintenance	Section-4
<ul style="list-style-type: none">• General Maintenance• Cleaning• Rear Shock• Pivot Points• Maintenance Schedule• Service Log	
Warranty & Service	Section-5
<ul style="list-style-type: none">• Frame Warranty• Service Centers	

SPECIFICATIONS ML7

Frame material:	6000-Series T6 Aluminum
Construction:	Butted drawn tubing Cold forged drop outs and lugs Double pass, smooth welding throughout
Head angle:	69.0 degrees
Seat Angle (effective):	72.0 degrees
Wheelbase (size specific):	1090 - 1150mm
BB Height (2.30 tire):	348 mm
Suspension Type:	Monolink - 15° wheel path
Rear Shock:	Maverick proprietary design. Cartridge oil damper, internal coil spring with air assist
Travel:	100 mm (4.0")
Rear Spacing:	135 mm
Brake system:	Disk only
Headset:	Internal, Campagnolo Standard
Seat Post Size:	30.9 mm
Seat Post Binder:	Maverick Custom polished
Bottom Bracket width:	73.0mm

GENERAL MAINTENANCE

After every ride we recommend that you inspect the frame and suspension for wear or damage that may have occurred - especially if you've crashed. A quick visual inspection of the following is normally all that is required. If you find anything questionable, have it inspected by your professional mechanic or bike shop.

- look over the frame tubes for any dents, deformation or cracks.
- Compress the suspension several times to check for proper spring force and rebound damping. If you do not know what the proper feel of the suspension is, learn! Have your mechanic or someone knowledgeable teach you.
- Rock the wheels sideways to feel for loose pivots, bearings or headset.
- Every two weeks check the pressure in the shock.
- Check the rubber shock boot to make sure it is properly attached and positioned* and that air vent holes face forward.

WASHING AND CLEANING

After you ride, if the chassis is muddy or the soil in your area is corrosive, a thorough wash should be performed. We recommend using the cleaner "Simple Green" mixed with warm water. Do not use cleaners containing bleach, acid or lye, as this may damage the frame finish. Rinse with water, but do not spray with full pressure directly at the suspension pivots, headset or shock. Avoid high pressure spray washers. When finished, wipe the chassis down with a towel.

Armor All, spray wax, or rust preventative sprays may be used, but do not use abrasive polishes on the anodized surfaces.

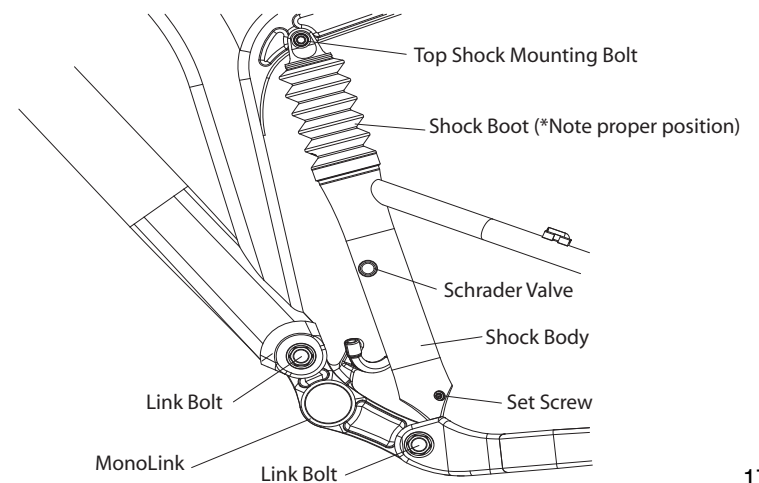

ADVANCED TUNING

OIL VOLUME:

If you find you are using too much of the suspension travel or bottoming out too easily, you can add oil to the rear shock to make the spring force firmer in the later stage of the travel. It will not help much with setting proper sag, but it will prevent beginning of the travel from getting harsh if you were to just to increase air pressure to stop bottoming out.

Factory-set oil volume: ML7: 7ml; ML7/5: 10ml; ML8: 15ml (Maximum total volume: 20ml)

To change the oil level, release the air pressure from the shock and remove the core from the schrader valve. Compress the shock completely. Fill a syringe with 3ml of Maverick "Gunna Flow" or other 80w assembly oil and put the tip into the schrader valve hole. Now extend the shock while gently compressing the syringe. This should suck the oil into the shock. Install the schrader core and pressurize. To remove oil, take out the valve core, turn the bike sideways and compress the shock, oil should exit the valve.

This chart shows the effect of different oil levels on spring force

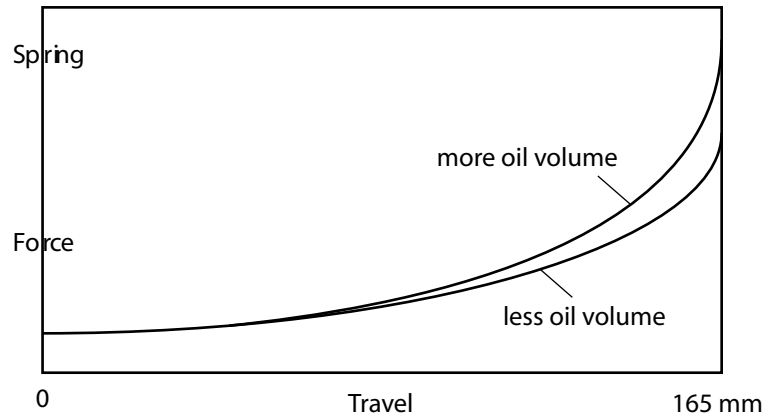

DAMPER VALVING:

The damper of any Maverick rear shock can be disassembled and tuned by altering the rebound shim stack and changing oil viscosity. This is for advanced mechanics only, outfitted with the proper special Maverick shock tools. Visit the "owner tech" section of our web site for details.

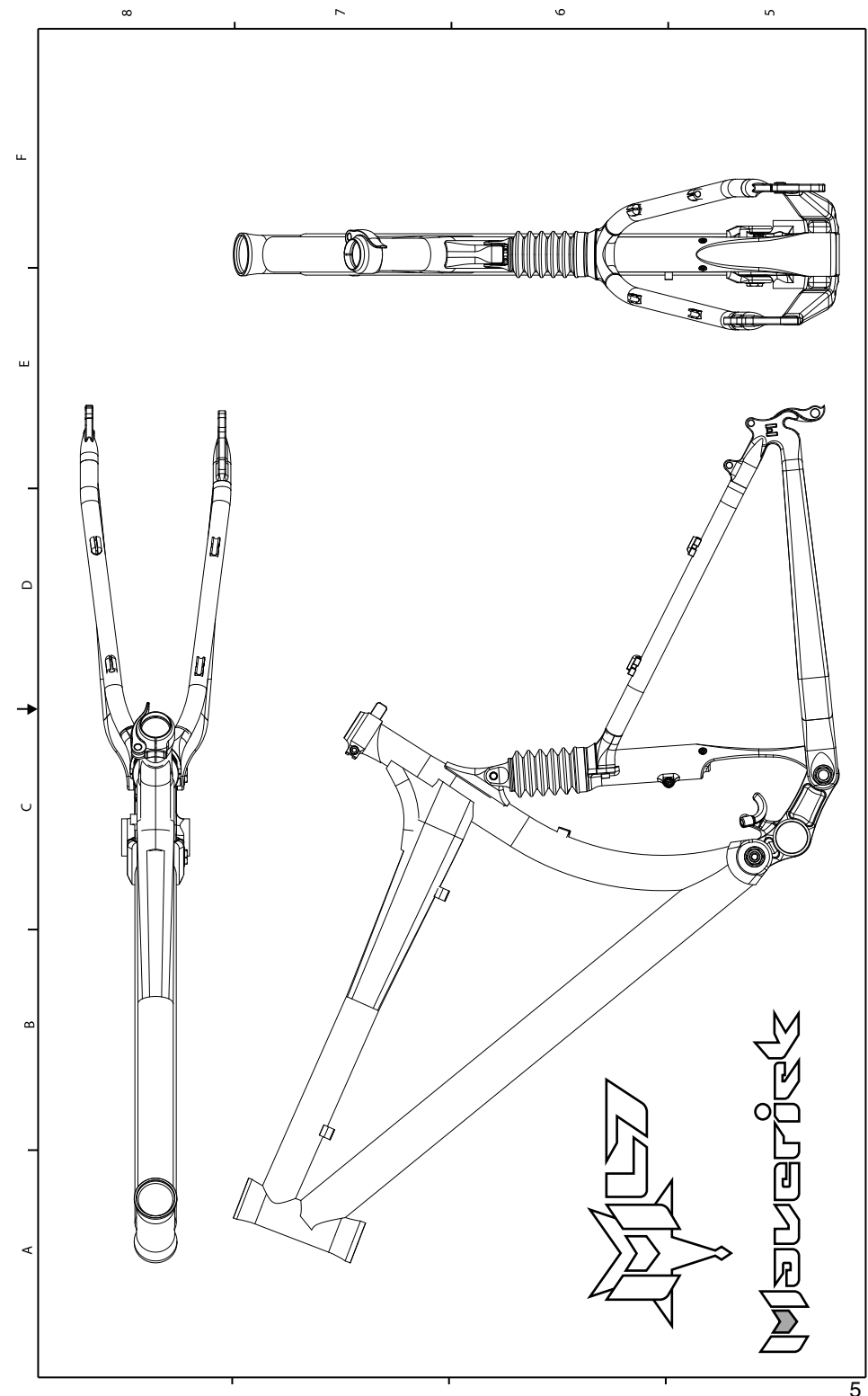

SPECIFICATIONS
ML7/5

- Frame material:** AL6069-T6 Aluminum
- Construction:** Custom drawn tube mix
Integral welded rear triangle/ shockbody
Cold forged drop outs and lugs
- Head angle:** 68.5 degrees
- Seat Angle (effective):** 71.0 degrees
- Wheelbase (size specific):** 1096 - 1151mm
- BB Height (2.30 tire):** 348 mm
- Suspension Type:** Monolink - 15° wheel path
- Rear Shock:** Maverick proprietary design air spring with cartridge oil damper
- Travel:** 127 mm (5")
- Rear Spacing:** 135 mm
- Brake system:** Disk only
- Headset:** Internal, Campagnolo Standard
- Seat Post Size:** 30.9 mm
- Seat Post Binder:** Maverick custom polished
- Bottom Bracket width:** 73.0mm

DAMPER REBOUND ADJUSTER

The adjuster knob is located at the top of the rear shock. Turning the red knob will determine how fast the suspension rebounds (extends) after it has been compressed. After the air pressure has been set correctly, adjust the rebound to your preference by turning it clockwise (direction of tightening a screw) for slower rebound, counter-clockwise for faster. There is about 1½ turns of adjustment.

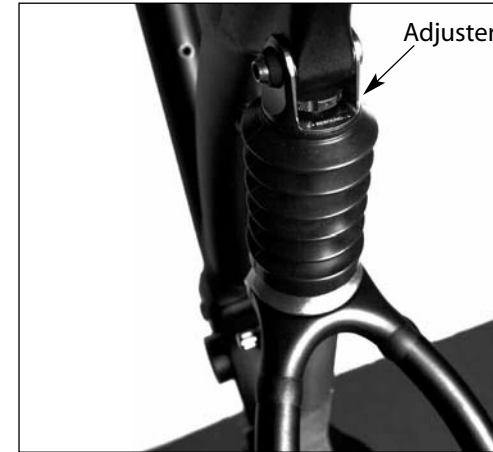

NOTE: during initial set-up, you should turn the knob to the slowest position (full clockwise) and adjust from there.

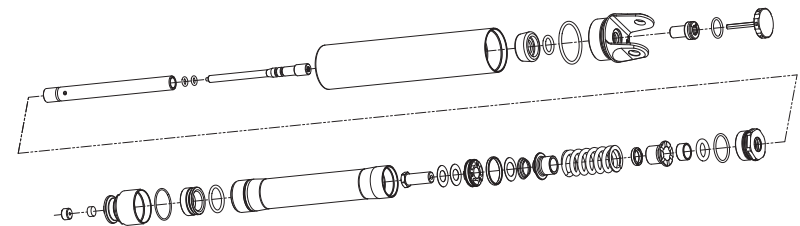

(Illustration for reference only - The ML7 and ML 7/5 use different dampers)

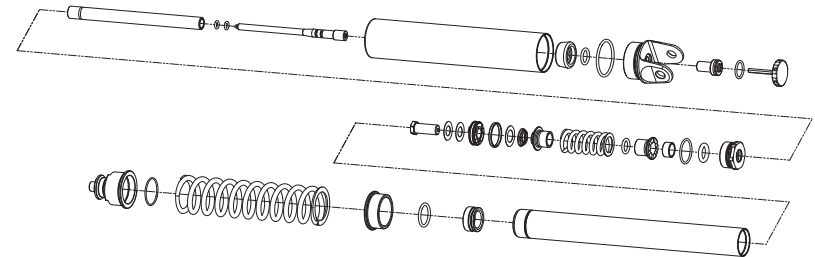

The ML8 rear damper assembly

SUSPENSION SAG

Preferred Set Up

The rear shock uses air pressure for its spring force. The spring force is what extends the suspension back up after it has been compressed and it must be adjusted for different rider weight, terrain or riding preference. When properly set-up, the suspension should compress about 25-to-30% of its travel when the rider's full weight is on the bike. The initial compression is called sag, and is adjusted by changing the air pressure in the shock.

Sag measurements: ML7: 15-17mm
 ML7/5: 19-23mm ML8: 19-23mm

It is easiest to check the suspension sag using two people. Measure the distance between the center of the upper shock mounting bolt and the bottom of the knurled ring on the shock body. Do this both with and without the rider's full weight on the bike in a normal riding position. Be sure the shock is fully extended before taking the first measurement. Take a couple of measurements after the rider has repositioned on the bike to find an average.

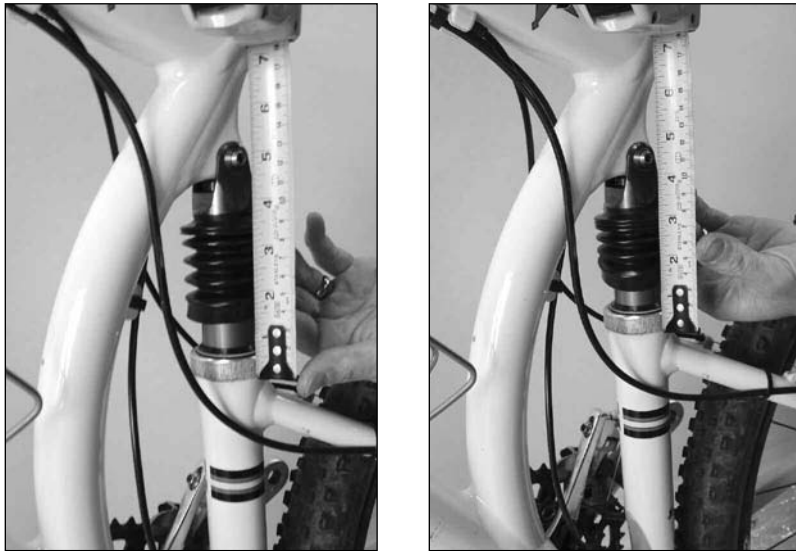

Approximate Pressure Settings for Rider Weight
 (Use sag measurements for best performance)

Rider Weight	Shock Pressure - PSI	Shock Pressure - BAR
< 55 kg (120 lbs)	80 - 105	5 - 7
55-75 kg (120 - 165 lbs)	105 - 150	7 - 10
75-95 kg (165 - 210 lbs)	150 - 190	10 - 13
> 95 kg (210 lbs)	190 - 250	12 - 16.5

DO NOT EXCEED 250 psi (16.5 BAR) IN THE REAR SHOCK

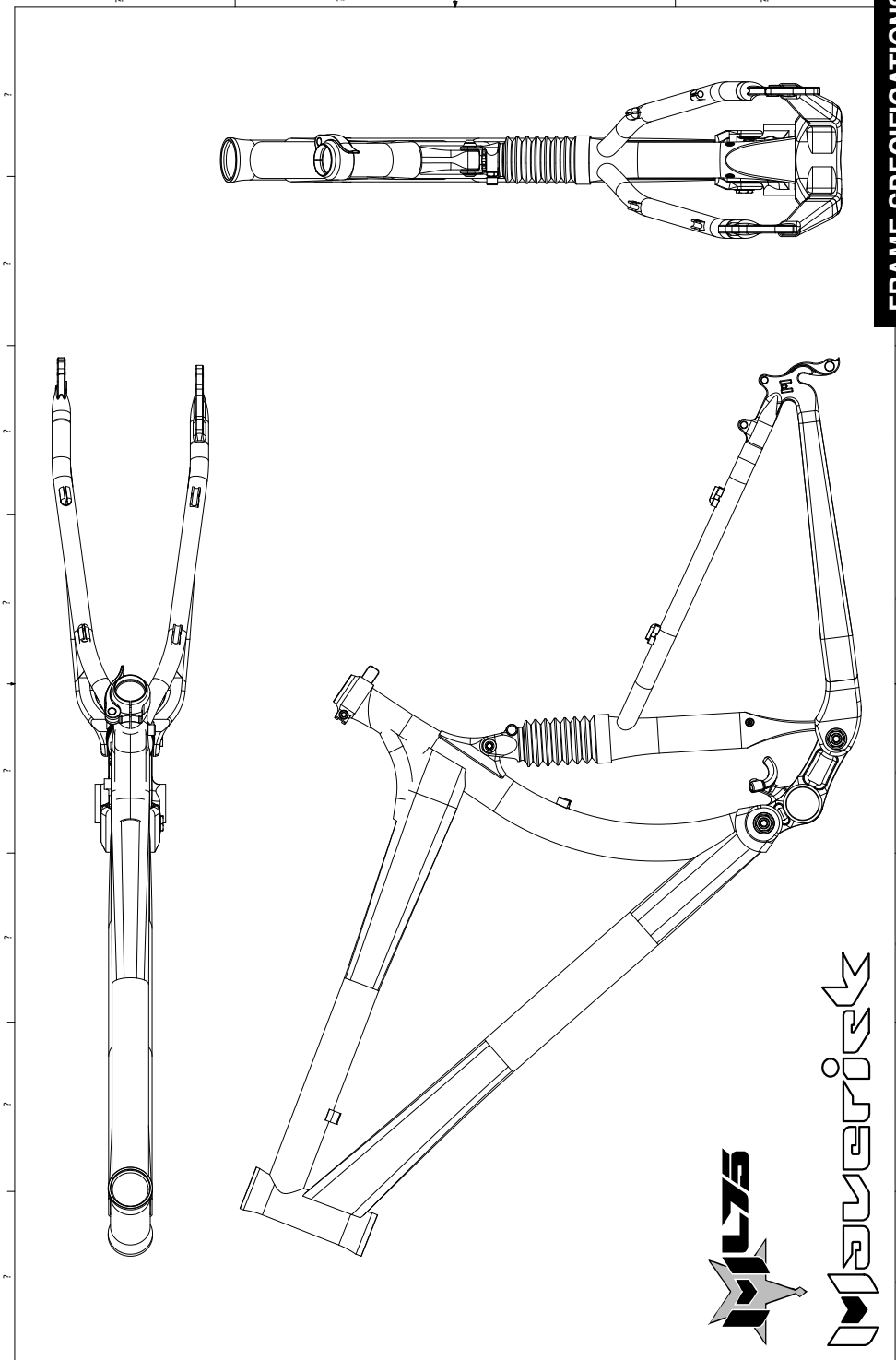

FRAME SPECIFICATIONS

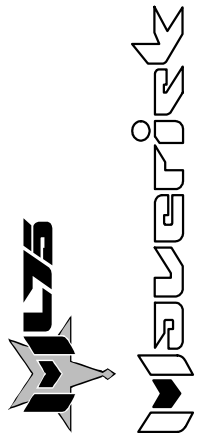

SPECIFICATIONS
ML8

Frame material:	AL6069-T6 Aluminum
Construction:	Monocoque/drawn tube mix Integral welded rear triangle/ shockbody Cold forged drop outs and lugs
Head angle:	68.5 degrees
Seat Angle (effective):	71.0 degrees
Wheelbase (size specific):	1096 - 1151mm
BB Height (2.30 tire):	348 mm
Suspension Type:	Monolink - 15° wheel path
Rear Shock:	Maverick proprietary design. Cartridge oil damper, internal coil spring with air assist
Travel:	165 mm (6.5")
Rear Spacing:	135 mm
Brake system:	Disk only
Headset:	Internal, Campagnolo Standard
Seat Post Size:	30.9 mm
Seat Post Binder:	Maverick Custom polished
Bottom Bracket width:	73.0mm

REAR SHOCK PRESSURE

Once your bike is built up you must adjust the rear shock for your individual weight and riding preferences. This entails adding or removing air pressure and setting the rebound damping adjuster.

Maverick recommends setting your rear shock pressure equal to approximately 90-to-100% of your weight when fully dressed for riding. For example, if you weigh 200 lbs. with shoes, water pack, etc., then you would set the shock pressure to 180-200 psi.

Please note that this is just an approximation. You may require significantly more or less pressure depending on how you sit on the bike, your riding style, or just how you prefer your suspension to feel.

You should also experiment with different settings to learn how the bike reacts. You will find that different pressures work better for different conditions. For example, if you are going to ride tight, twisty singletrack, you might increase the pressure to steepen the steering angle. Steep downhill riding and/or soft, sandy conditions might require lower air pressure to prevent the front wheel from diving in the turns.

To change the pressure in the rear shock, attach a standard high pressure shock pump to the schrader valve located on the left side of the shock as shown.



NOTE: upon removal of the pump, the pressure in the shock is what was read on the gauge. The small amount of air heard escaping during removal is the air that was inside the pump. When re-installing the pump, the pressure will read slightly lower because air from the shock fills the pump.

CABLE ROUTING

We recommend routing the shifter cable and brake hose around the shock as shown.

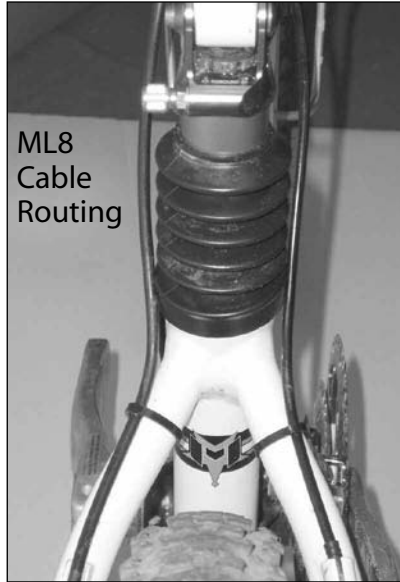

Note: Use the supplied clear vinyl stickers to protect the frame from wear caused by cables rubbing against the frame.

Use a small "ZIP TIE" to secure brake line to frame as shown

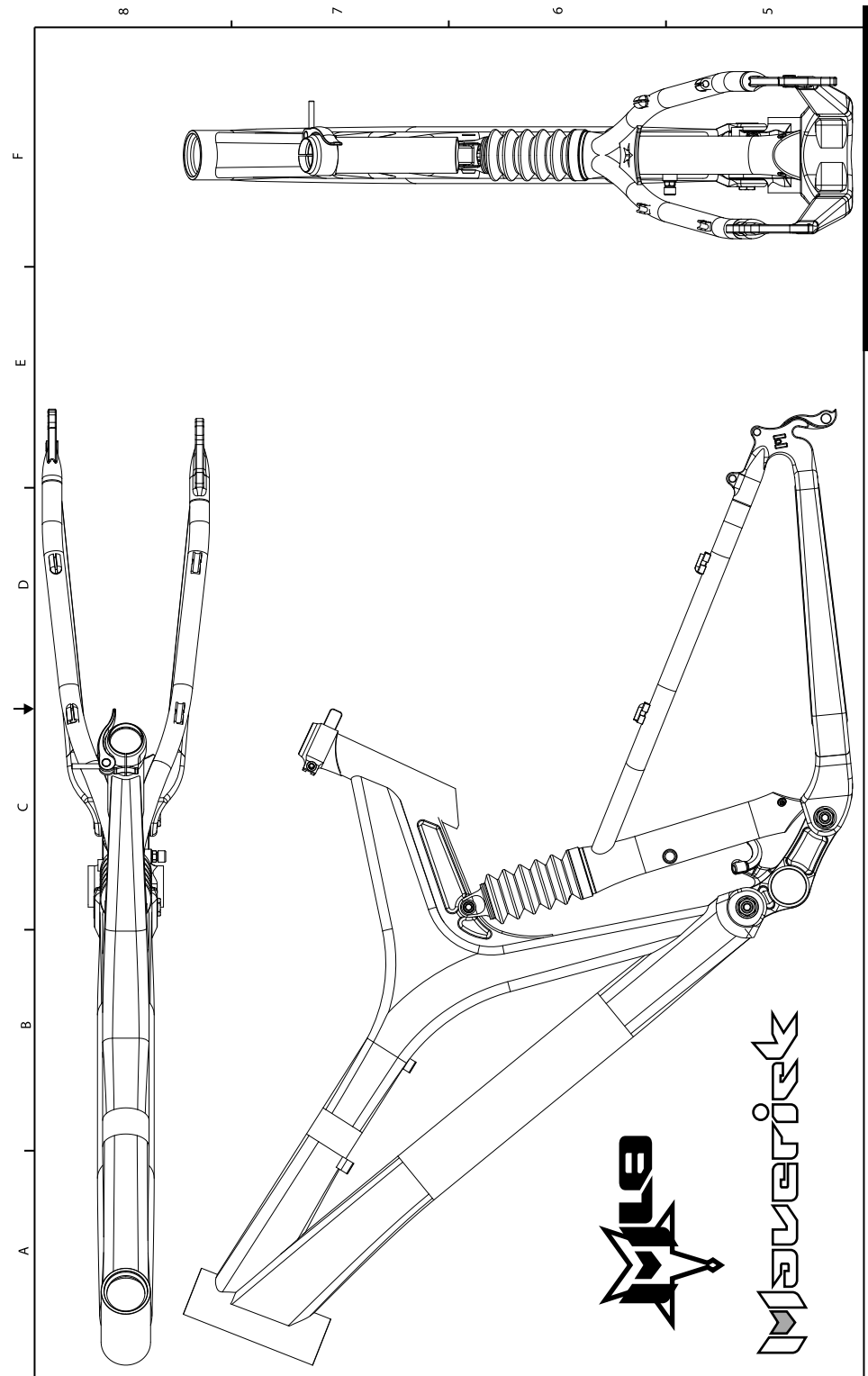
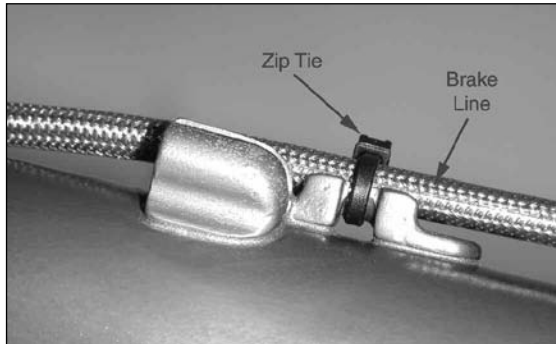

ASSEMBLY OVERVIEW

Maverick framesets must be assembled into complete bikes by a competent mechanic using proper tools. Improper assembly can reduce performance, cause premature failure or wear of critical components, and could lead to loss of control resulting in severe injuries.

On the following pages you will find information on the assembly requirements or techniques pertaining to Maverick framesets. Specific information about the components you choose to install on the frame should be gathered from the manufacturers of those components.

REQUIRED COMPONENTS

FORK:

The ML7 and ML7/5 require a front fork with 125-150 mm of travel, with a crown race- to-axle measurement of no less than 505 mm. We suggest that you build your ML7 or ML7/5 with the Maverick SC32 or DUC32 fork as the geometry, stiffness and tuning are designed for and complement these frames. We recommend the 6" travel DUC32 fork for the ML8 frame.

HEADSET:

Maverick frames are designed for and can ONLY use an internal headset with a 42.0 mm Campagnolo standard bearing. These are available from FSA Components and Cane Creek.

BRAKES:

Disk brake only, with an international standard mounting.

SEATPOST:

The required seatpost size is 30.9 mm. We recommend using only a strong, high quality post with enough forward tilt of the saddle to allow for the frame's relaxed seat tube angle. **On the ML8, be careful not to lower the post so far as to interfere with the operation of the rear shock. No more than 60 mm of seatpost should extend below the seat tube.**

FRONT DERAILLEUR:

Maverick frames are designed to use the proprietary Maverick "D-Mount" which allows the use of a Shimano braze-on front road derailleur. The ML7, ML7/5 and ML8 frames can only use a braze-on front derailleur.

FRONT DERAILLEUR MOUNTING

All Maverick framesets use the supplied D-Mount bracket to attach the front derailleur to the MonoLink. Install the D-Mount as shown with no spacers between it and the MonoLink.

(Note: Maverick framesets can only use a Shimano braze-on road triple front derailleur)



Fig. 1

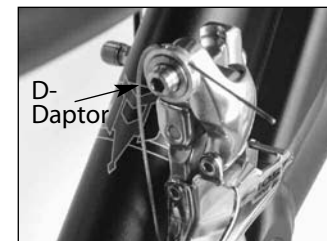

Fig. 2

FRONT DERAILLEUR SET UP:

Route the derailleur cable through a short piece of Teflon cable housing liner under the MonoLink cable guide.

D-DAPTOR SET UP:

Unscrew the cable anchor bolt and remove the stock washer. Slide the bolt through the front of the D-Daptor (with washer and pocket facing rear), and thread loosely into the derailleur. Run the derailleur cable into the opening on the back of the D-Daptor, pulling the cable away from the bike (see figure 2). Looking from the rear of the frame, align the D-Daptor cable angle at approximately 45 degrees downward. Set the barrel adjuster 1-1/2 turns out and tighten the anchor bolt to 60-70 in. lbs.

RECOMMENDED FRONT DERAILLEURS:

		Front Derailleur	D-Daptor	Application
(1)	Best	Shimano R773 Flat Bar Triple	No	All Maverick Frames
(2)	Good	Shimano 10-speed 105 Triple	Yes	All Maverick Frames
		Shimano Dura-Ace Triple	Yes	All Maverick Frames
		Shimano 105 9-speed Triple	Yes	All Maverick Frames
(3)	Good	Shimano R443 Flat Bar Triple	No	ML7 Only

Notes:

- 1) The Maverick D-Daptor helps match the cable pull of a MTB shifter to a road triple front derailleur. See section (2) of the chart above.
- 2) Be sure to set correct sag on shock before adjusting. (See page 21 of manual)
- 3) Use the barrel adjuster on the front shifter while sitting on the bike for final small-to-middle chainring adjustment.
- 4) Be sure that the outer derailleur cage is parallel to the large chainring.
- 5) Follow manufacturers instructions for chainring clearance and height adjustment.

ASSEMBLY INFORMATION